

BFI57

Basic Flight Instrument



P/N 57BFI-(xxx)-(xxx)

Operation and Installation

(Dokument-Nr. 08.510.010.71e)

List of Changes

| Revision | Date | Change Description |
|----------|------------|------------------------------|
| 1.00 | 04.10.2010 | First Issue |
| 1.01 | 24.11.2010 | Power Consumption |
| 1.02 | 26.11.2010 | Correction Delivery |
| 2.00 | 25.05.2011 | Software 2.00, Cable Changed |

List of Service Bulletins (SB)

Service bulletins are to be inserted in the manual and to be recorded in the table.

| SB Number | Rev. No. | Issue Date | Date of Insertion | Name |
|-----------|----------|------------|-------------------|------|
| | | | | |
| | | | | |
| | | | | |
| | | | | |
| | | | | |
| | | | | |

Device Overview

| Article Number | Description |
|-----------------------|---------------|
| P/N 57BFI-(000)-(000) | Basic variant |

TABLE OF CONTENTS

| | | |
|-------|---|----|
| 1 | INTRODUCTION..... | 5 |
| 1.1 | Symbols | 5 |
| 1.2 | Customer Service..... | 5 |
| 1.3 | Device Overview | 6 |
| 2 | OPERATION | 7 |
| 2.1 | Operation Controls | 7 |
| 2.2 | Switching ON/OFF | 8 |
| 2.3 | Display | 9 |
| 2.3.1 | Primary Flight Information | 9 |
| 2.3.2 | Elements of the Third Line..... | 10 |
| 2.4 | Operation of QNH (Manually and Automatically) | 14 |
| 2.5 | Settings | 17 |
| 2.5.1 | Layout of the Setting-Mode | 17 |
| 2.5.2 | Setting Options – Step by Step | 18 |
| 2.6 | Battery Care | 20 |
| 2.7 | Calibration | 20 |
| 3 | INSTALLATION..... | 21 |
| 3.1 | Unpacking and Inspection..... | 21 |
| 3.2 | Scope of Delivery | 21 |
| 3.3 | Available Accessory | 21 |
| 3.4 | Mounting | 22 |
| 3.5 | Device Connectors..... | 22 |
| 3.5.1 | GPS Antenna | 22 |
| 3.5.2 | Pressure Inputs | 23 |
| 3.5.3 | Power / RS-232 | 23 |
| 3.6 | Device Dimensions | 24 |
| 3.6.1 | Housing | 24 |
| 3.6.2 | Installation Hints..... | 25 |
| 3.7 | Post-Installation Checks..... | 25 |
| 3.8 | Device Configuration..... | 26 |
| 3.8.1 | Switching-On Behaviour | 26 |
| 3.8.2 | Charging Behaviour..... | 27 |
| 3.8.3 | IAS Tape – Colour Markers..... | 27 |
| 3.9 | Firmware Update..... | 29 |
| 4 | STORAGE AND DISPOSAL | 30 |

| | | |
|-------|---------------------------------------|----|
| 5 | APPENDICES | 31 |
| 5.1 | Technical Data | 31 |
| 5.2 | Outputs at the Serial Interface | 32 |
| 5.2.1 | Output Protocol | 32 |
| 5.2.2 | GPS Messages | 32 |
| 5.2.3 | BFI57-specific Output Messages..... | 32 |

1 INTRODUCTION

This manual contains information about the physical, mechanical and electric qualities and the description of installation and operation of the basic flight instrument BFI57.

1.1 Symbols

| | |
|---|--|
|  | <p>Vital information that if not followed may cause damage in the device or in other parts of equipment or may have a negative impact on the correct function of the device.</p> |
|---|--|

| | |
|---|--------------------|
|  | <p>Information</p> |
|---|--------------------|

1.2 Customer Service

For fast handling of returns please follow the instructions on the form for complaints and returns provided in the **service area** of the Funkwerk Avionics website **www.funkwerk-avionics.com**.

| | |
|---|--|
|  | <p>Suggestions for the improvement of our manuals are welcome. Contact: service@funkwerk-avionics.com.</p> |
|---|--|

| | |
|---|---|
|  | <p>Information about software updates is available from Funkwerk Avionics. The description of the update procedure can be found in chapter 3.9.</p> |
|---|---|

1.3 Device Overview

The BFI57 is a compact display unit presenting the basic flight informations in one single unit. Thanks to it's integrated battery and sophisticated charge management, besides for minimum instrumentation it also can be used as aircraft-power independent backup-device for ultralights with glasscockpits.

The integrated GPS receiver allows automatic QNH determination with one single key press – if you like, even without any further interaction whenever powered up, so that pilot's action can be reduced to switching on and off.

The automatic timing of the last flight supports the pilot in filling out his flight log; returning to the home airfield is assisted by displaying direction and distance.

The output of the pressure derived measurements and GPS positions on the serial interface allows the use of the device as secondary (redundant) sensor for glasscockpits or other displays.

As the device can be configured for automatic starting whenever power is applied, it additionally can be used as sensor for automatic flight data collection; in this case, the device prevents being switched off manually.

2 OPERATION

2.1 Operation Controls

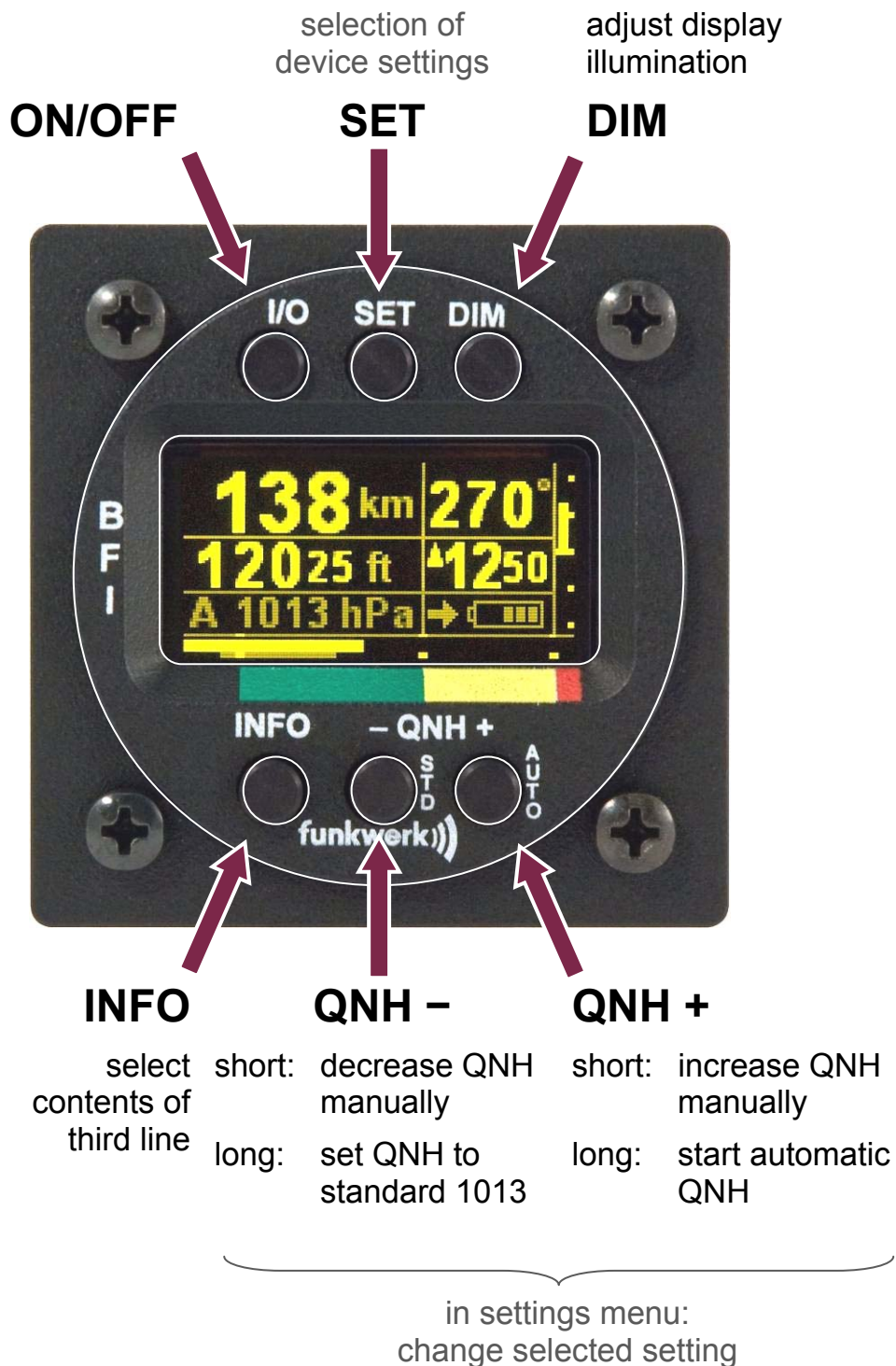

| | |
|--------------|--|
| I/O | Switch ON (press 1 sec, display may be somewhat delayed), Switch OFF (press long), Restart (press 10 seconds) |
| SET | Toggle between Normal and Setup mode |
| DIM | Selection of three different display illuminations HI → LO → all white / no grey |
| INFO | Change between the different pre-defined contents of the third line |
| - QNH | <u>Normal Mode:</u> - short keypress: decrease QNH manually - long keypress: select STD QNH 1013 hPa / 29,92 inHG <u>Setup Mode:</u> - Adjusting and selecting values |
| QNH + | <u>Normal Mode:</u> - short keypress: increase QNH manually - long keypress: start AUTO matic QNH determination <u>Setup Mode:</u> - Adjusting and selecting values |

2.2 Switching ON/OFF

Depending onto the configured power-on behaviour (see 3.8.1), the device is either turned on manually, or it automatically turns on when aircraft power is applied.

After switching on, the following splash screen appears (may be somewhat delayed):

e.g.  Company Logo
 Device Type
 Software-Version
 Batterymanagement-Firmware-Version

If the capacity of the battery is significantly reduced due to aging, a “Bad Battery!” message is indicated on the splash screen.

In this case the battery should be exchanged as soon as possible, as otherwise the autonomous operation cannot be guaranteed!



The device can be rebooted with pressing of **I/O** for about 10s.

2.3 Display

After the splash screen the display changes into normal mode by default. Another Display Mode is the Setup Mode. Both modes can be accessed (toggled) with **SET**.

2.3.1 Primary Flight Information

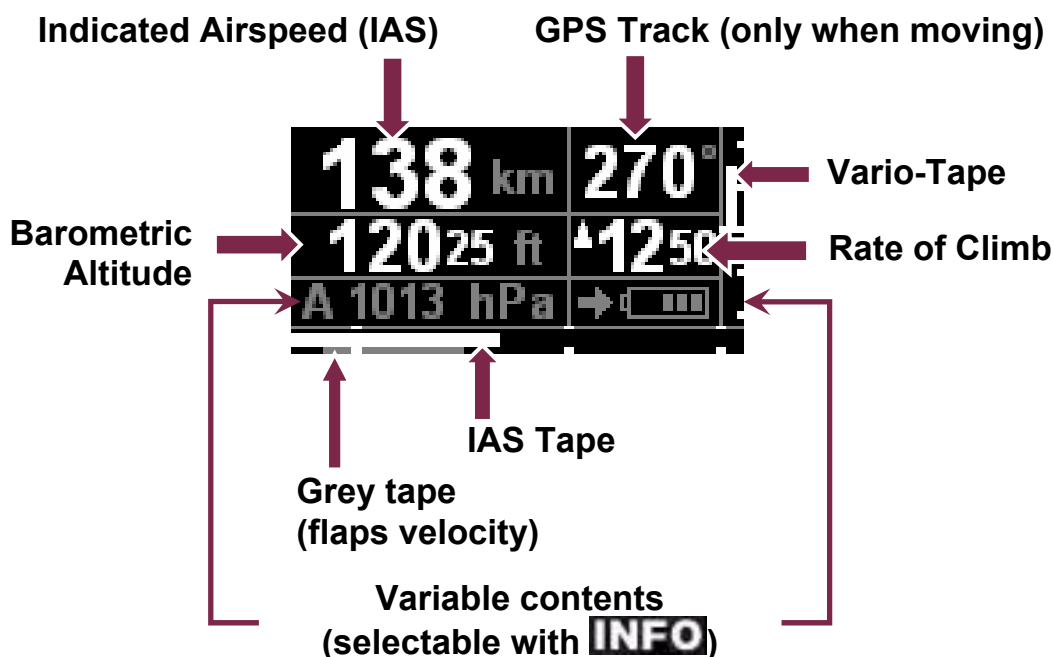

While essential informations like airspeed, altitude, track and rate of climb are displayed permanently, the content of the third line is selected out of a predefined set (described in section 2.3.2).

Airspeed (IAS), Altitude (ALT) and Rate of Climb (RoC) are pressure derived values; the altitude depends onto the selected QNH setting.

The units in which airspeed, altitude, rate of climb and the QNH are indicated are configurable (see 2.4). It can be chosen from the following units:

Speed (IAS).....kt (knots) or km/h (kilometres per hour)

Altitude (ALT).....ft (feet) or m (meter)

Rate of Climb (RoC) .ft/min (feet per minute) or m/s (meter per second)

If altitude and rate of climb are given in ft or ft/min respectively, the last two numbers are shown downsized. As the rate of climb is shown without a unit designator the layout of the numerical value (last two digits downsized) gives information on the unit used.

0.0 → m/s (mps)

000 → ft/min (fpm)

The indication of the GPS track relies on the availability of the GPS signal. In case there is no or bad availability the GPS track numerical value is replaced by “---”.

When standing still (neither flying nor taxiing) no GPS track will be indicated.

| | |
|---|--|
|  | <p>GPS reception (sufficient satellites available) can be identified by the indications of GPS track and position (see page 13).</p> |
|---|--|

Besides the numerical values of speed and rate of climb tape indicators can be found additionally:

Tape indicator – Airspeed

The tape indication for the airspeed is located at the lower edge of the screen. With respect to the colour bands printed on the device’s housing below the screen one can determine aircraft specific velocity ranges. Those ranges must be correctly defined in the device configuration (see 3.8.3).

Tape Indicator – Rate of Climb

The tape indication for the rate of climb is located at the right edge of the screen. The range of the scale is adjustable from a pre-defined set of values (see 2.5.2.6)

2.3.2 Elements of the Third Line

The variable **content of the third line can be changed by pressing **INFO** several times.**



After starting up the device, the third line shows the **QNH** and the **battery status** by default.

| | |
|---|---|
|  | <p>The default view (QNH + Battery Status) can be accessed from any of the following pages by a long keypress of INFO.</p> |
|---|---|

2.3.2.1 Battery Indication

The battery symbol reflects the charge state of the battery. In case the battery is not charging and the charge state is low, the battery symbol will be depicted in white instead of grey. If the charge state becomes critical, the symbol will additionally be inverted:



An arrow  in front of the battery symbol indicates an active charging process, a check mark  the completed charging.

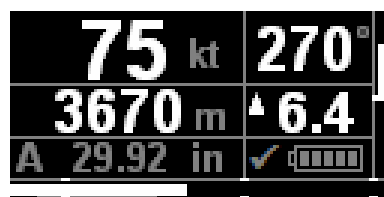

At temperatures significant below the freezing point (below $-5^{\circ}\text{C}/+23^{\circ}\text{F}$) the charging functionality is reduced, and the battery state cannot be determined correctly during charging. In this case the battery symbol changes to the display , until the temperature rises again. Even in this case, however, the discharging use (use of the device without having aircraft power supply) is still possible.

| | |
|---|--|
|  | <p>At extreme temperatures (below $-15^{\circ}\text{C}/+5^{\circ}\text{F}$ and above $+45^{\circ}\text{C}/+113^{\circ}\text{F}$) the battery cannot be charged, as otherwise it would be damaged permanently.</p> <p>The discharging use however (use of the device without having aircraft power supply) is still possible.</p> |
|---|--|

2.3.2.2 QNH Indication

The QNH indication gives the pressure setting, which is used for the determination of the baro-altitude. The unit of the QNH is configurable (see 2.5.2.2). Additionally it is indicated whether the QNH was set manually (M) or determined automatically (A).

The automatic QNH-determination is started by a long press of **QNH +** gestartet; see (ch. 2.4) for **QNH management**.

While the automatic QNH-determination is in progress (this requires a valid GPS position), the numerical value for the QNH is substituted by „----“. During this indication the last QNH value is

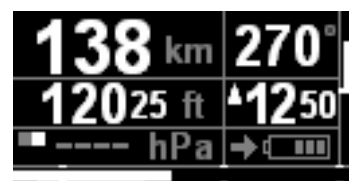

used; in case directly after being switched on this is the standard value 1013hPa / 29.92inHG.

2.3.2.3 Flight Time



(in flight)



(after landing)

After pressing **INFO** the flight time is indicated. During flight the duration airborne is indicated, after landing additionally the start and landing time are given (in UTC).

| | |
|---|--|
|  | <p>Starts and landings are defined by the configured aircraft minimum velocity (lower limit of the green or white colour band, see 3.8.3.1 and 3.8.3.5).</p> |
|---|--|

2.3.2.4 Return-Home Aid

After pressing **INFO** again – when having GPS reception – the distance and true direction to the configured home airfield (see 2.5.2.9) are displayed.



2.3.2.5 Groundspeed



After pressing **INFO** again the groundspeed is shown in the third line. The groundspeed is always shown in the same unit as the airspeed (IAS) is indicated. This unit is configurable to be **km/h** or **kt** (see 2.5.2.7).

In case GPS is not available, the groundspeed cannot be determined and the numerical value is replaced by “---”.

2.3.2.6 Position (Latitude and Longitude)

After pressing **INFO** again the GPS coordinates are shown. At first the Latitude will be displayed. Pressing **INFO** once more shows the Longitude.



The format in which the coordinates are given be configured to be either *Degree°Minute'Second* or *Degree°Minute.Centiminate*' (see 2.5.2.8).

In case there is no GPS available, the position values are replaced by "----".

2.3.2.7 Time (UTC)

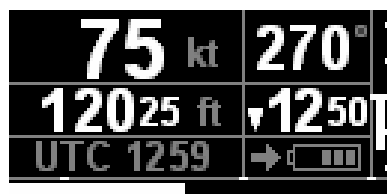

After pressing **INFO** again the time is indicated (in UTC).



In case GPS is not available, the time cannot be determined and the indication is replaced by "----".

2.4 Operation of QNH (Manually and Automatically)

The QNH can be set using three methods:

1. Manually by entering values with short presses of **- QNH +**.
2. Manually set to the standard value 1013 hPa / 29.92 inHG with a long press of **- QNH**.
3. By automatic determination from comparison of the measured static pressure with the GPS altitude. This is started with a long press of **QNH +**. The QNH will now be determined **once**. To repeat the automatic determination, it has to be started again.

The GPS altitude has an inaccuracy of typ. < 80ft (25m).

The automatic QNH determination requires having a valid GPS position. For this position the device waits a predetermined duration. **If no GPS position could be determined during this duration, a notification is displayed shortly, and the QNH value from before starting the failed determination is continued to be used.**

Whether the automatic QNH determination was successful, can be seen by the updated QNH mode display:

- A** The QNH has been determined automatically.
- M** The QNH could **not** be determined automatically, or it was set manually.

This is depicted in the following diagram:

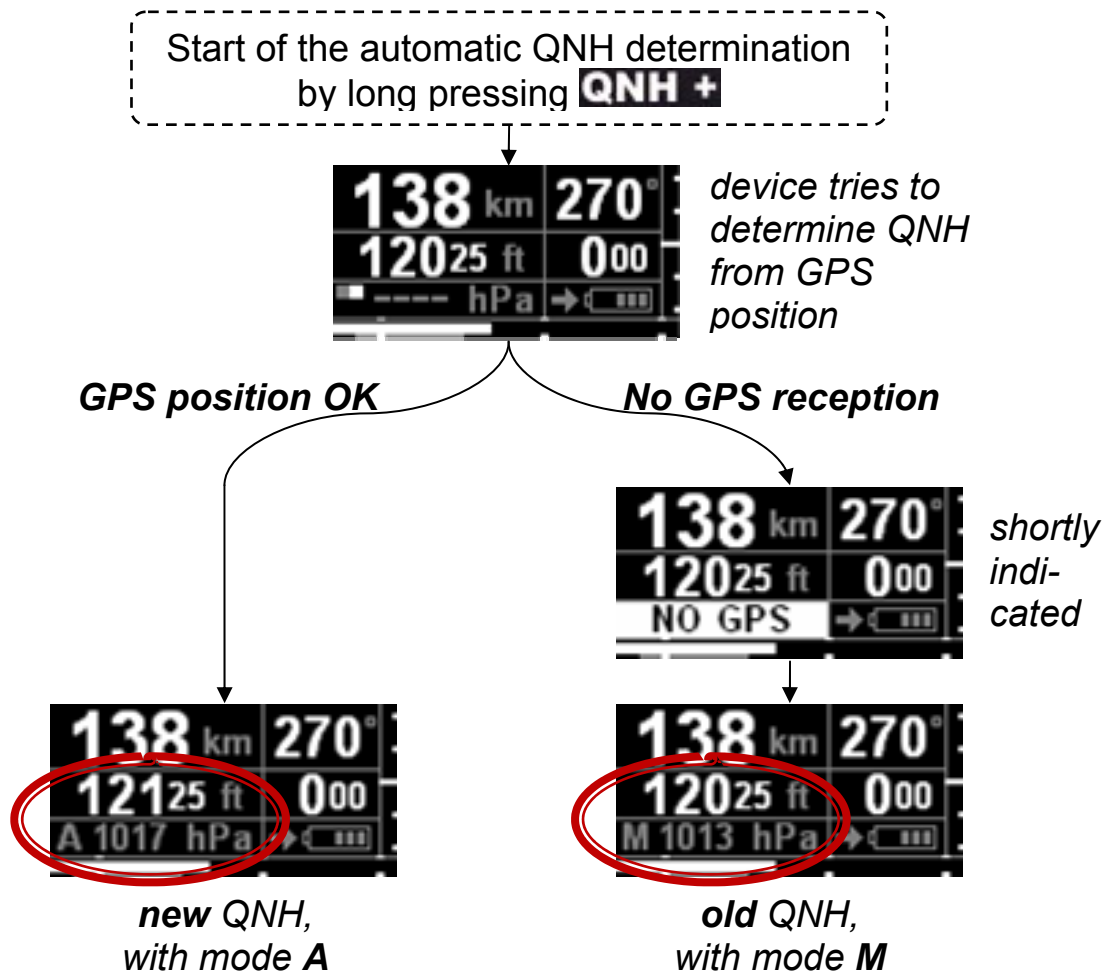

 As the vertical pressure gradient (the decrease of the static pressure with increasing altitude) varies with the weather, the **automatic QNH determination is most accurate close to the ground** in vicinity of the destination airport. If the automatic has been activated in greater altitudes, shortly before reaching the traffic circuit altitude another activation should be performed, to correct possible inaccuracies.

 The device can be set to perform the automatic QNH determination automatically once each time after being turned on (see 2.5.2.1).
With this, for short flights no interaction is required at all!

For cross-country flights the QNH can be handled as follows:

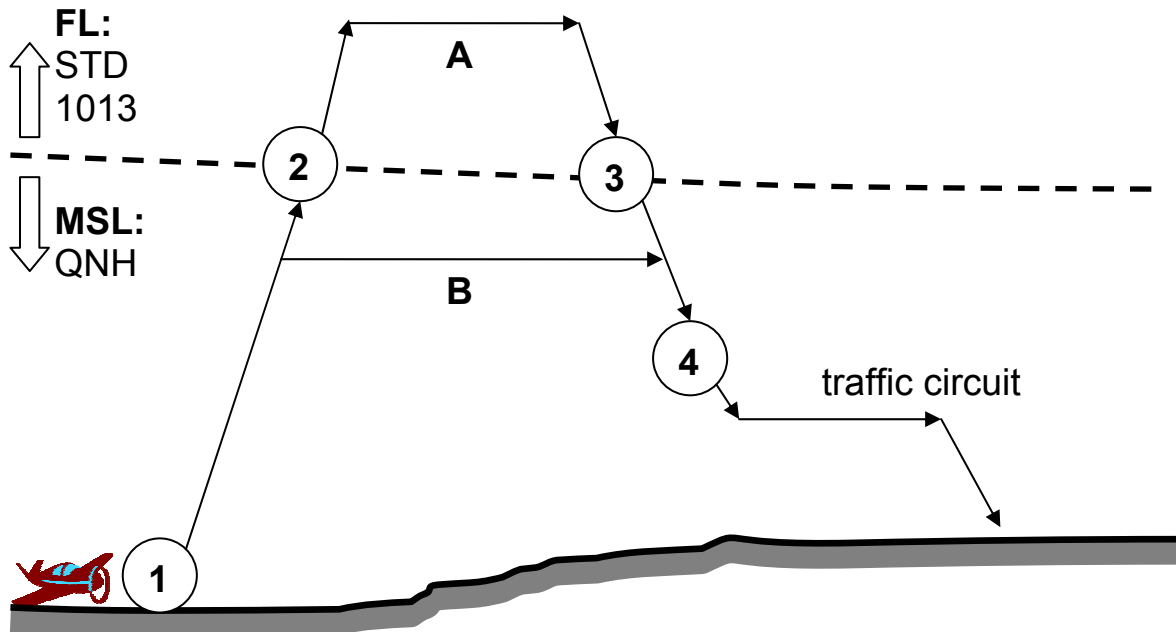

| | | | |
|-----|---|--|--|
| (1) | After being switched on / before start | determine QNH automatically | automatically or by a long press of QNH + |
| (2) | Crossing the Transition Altitude | set to 1013 hPa / 29.92 inHG STD, to fly Flight Levels | by a long press of - QNH |
| (3) | Going below the Transition Level | determine QNH automatically, to fly MSL | by a long press of QNH + for <u>approximately</u> setting the QNH |
| | | or manually | using - QNH / QNH + |
| (4) | Before reaching the traffic circuit ^{*)} | determine QNH automatically | by a long press of QNH + |

^{*)} Even if at (3) the automatic determination already has been performed, it should be activated again at (4) shortly before reaching the traffic circuit, as the vertical pressure gradient may deviate from the ICAO normal atmosphere, what potentially decreases the accuracy of the QNH determination at the large altitude of (3).

2.5 Settings

In the settings menu several options regarding the indications on the screen in normal operation can be adjusted:

- Activate the automatic QNH setting once each time when being turned on
- Units of Airspeed (km/h or kt), Altitude (m or ft), Rate of Climb (m/s or ft/min)
- Scale range of the Rate-of-Climb-Tape
- Format of the GPS-Position (Latitude / Longitude)

2.5.1 Layout of the Setting-Mode

Within the setting mode the third line is used to display and select the setting options.



From normal operation mode the settings mode can be accessed by pressing **SET** long.

While in setting mode the different settings can be **stepped through by pressing INFO**.

Any adjustment or selection of values is done with the setting buttons **- QNH +**. Currently active settings are marked with a white underscore.

The setting mode can be left by stepping through the complete set of settings or can be exited earlier by pressing **SET**.



Changes in the settings are stored and activated promptly, no separate confirmation is required.

2.5.2 Setting Options – Step by Step

2.5.2.1 Activate the Automatic QNH Setting Once each Time when being Turned On



This option allows to define whether the device initiates one automatic QNH determination each time after being turned on, or not.

In both cases the device starts with using the standard QNH 1013 hPa / 29,92 inHG.

The automatic setting of the QNH requires GPS availability, because the GPS altitude is used as a reference for determining the QNH. If no GPS position could be determined within a fixed time interval, the standard QNH is continued to be used, see p. 15.

2.5.2.2 Automatic Flight Time Display after each Landing

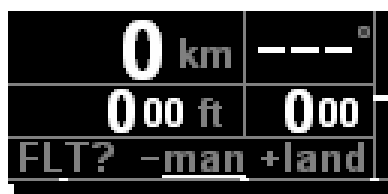

It is possible to select having the flight time displayed only after being selected manually (“man”) or additionally automatically after each landing (“land”).

2.5.2.3 QNH – Unit

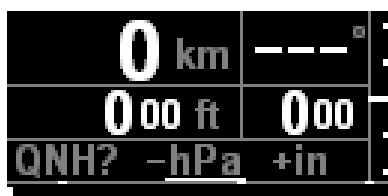

The QNH can be given in Hektopascal (hPa) or inch of mercury column (inHG).

The selection of the settings is done with the keys **- QNH +**.

2.5.2.4 Altitude – Unit

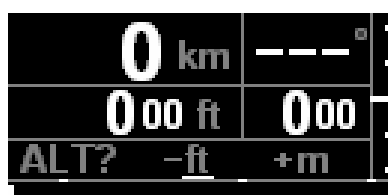

The altitude can be provided in feet (ft) or in meter (m). An additional cue for the values given in feet (ft) are the downsized last two digits.

2.5.2.5 Rate of Climb – Unit

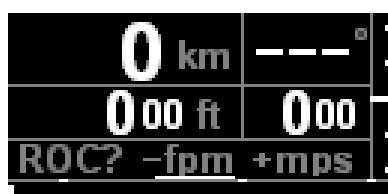

The rate of climb is provided either in meter per second (**mps**) or in feet per minute (**fpm**). The selected unit is reflected by the respective format of the numerical value:

fpm **000** no decimal digit, last two digits downsized

mps **0.0** one decimal digit, all digits same size

2.5.2.6 Large and Small Scale for Rate of Climb Tape Indication

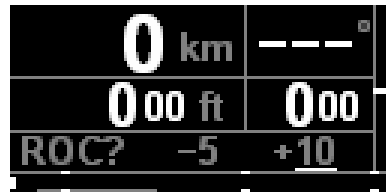

Depending on the selected unit the rate of climb maximum scale value (second marking) can be chosen to be ± 1000 ft/min resp. ± 5 m/s or to be ± 2000 ft/min resp. ± 10 m/s.

2.5.2.7 Indicated Airspeed (IAS) – Unit



The airspeed is either provided in **km/h** or in **kt**.

2.5.2.8 GPS Position – Format

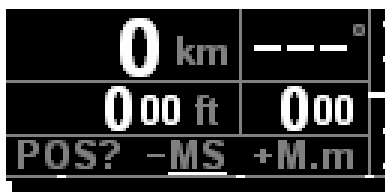

There are two different formats in which the GPS coordinates can be displayed.

MS Degree°Minute'Second'' 48°12'30'' N

M.m Degree°Minute,Centiminate 48°12,50' N

As this is the last option in the setting mode, the setting mode is now left by pressing **INFO**. The display changes back to the last selected screen in the normal operation mode.

2.5.2.9 Home Airfield – Geographic Location



When having GPS reception, the current position can be stored as new home airfield location for the return-home aid. The successful operation is indicated by displaying a check mark.

It is not possible to manually enter coordinates different from the current position.

2.6 Battery Care



Never store the device over extended periods with empty battery, as the resulting deep discharge would damage the battery permanently.



Significantly discharge the battery at least three to four times a year, by running the device for at least 3 hours on battery (i.e. without applying aircraft power).

This trains the battery, and it allows the device to measure the remaining battery performance.

Afterwards the battery should be recharged.

2.7 Calibration



In order to maintain the accuracy of the airspeed indicator and the altitude indicator, it is recommended to have the device recalibrated in regular intervals of 4 years – in case of severe operational conditions more often.

3 INSTALLATION

3.1 Unpacking and Inspection

Unpack the device carefully. Damages in transit must be immediately reported to the carrier. The original packaging material must be kept for proof.

| | |
|---|--|
|  | For storage or return please use the original packaging. |
|---|--|

3.2 Scope of Delivery

| Part Number | Description |
|-----------------------|---|
| BFI57 | Basic Flight Instrument BFI57, incl. Lilon battery |
| M4X8ZSW (4 pieces) | Mounting screw for panels with a thickness up to 5 mm |
| DA-1A03SMA | GPS Antenna with cable and SMA jack |
| BSKSBF12 | Power and data cable |
| 08.510.010.71e | Manual "Operation and Installation" |

| | |
|---|--|
|  | In terms of environmental protection the Lilon Battery has to be recycled separately and in a professional manner. |
|---|--|

3.3 Available Accessory

| Part Number | Description |
|-------------|---|
| ZATRUSB | Data cable for firmware update |
| 0095-05 | Data Connector Type Binder for RS232 data port, mating BSKSBFI2 |
| PNECAB80 | Replacement Lilon battery |

3.4 Mounting

- Avoid installing close to heat sources. Sufficient aerial circulation is necessary.
- When installing the cables and connecting plugs leave enough space for each.
- Sharp bending and routing of wires close to control cables should be avoided.
- The cables must be long enough so that plugs are accessible for repair.
- The cable harness that leads to the device connector must be placed so that condensation water can not leak into the plug.
- Cable sets and antennas are available at Funkwerk Avionics GmbH
- For installation tips and drawings see chapter 3.5.2 "installation tips".

3.5 Device Connectors

The BFI57 includes the following interfaces:

- GPS Antenna
- 2 x pressure (pitot and static)
- Power / RS-232 (NMEA output and maintenance)

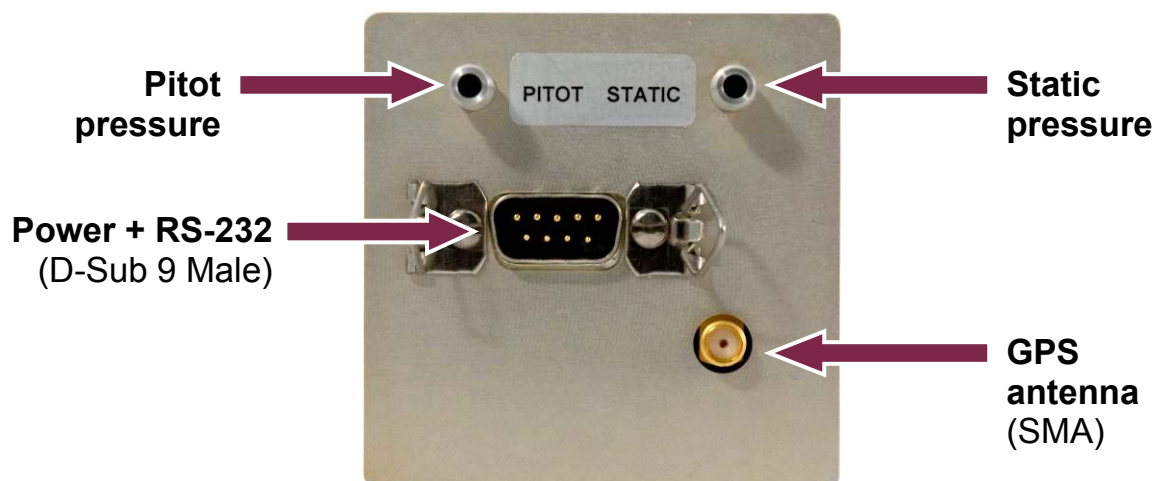

3.5.1 GPS Antenna

An SMA type socket provides the connection to the active (5V) GPS antenna that is supplied with the BFI57.

3.5.2 Pressure Inputs

Two pressure probes are providing the inputs for the sensor based determination of the indicated airspeed, the barometric altitude as well as the rate of climb.

3.5.3 Power / RS-232

By a 9-pole D-Sub socket (male) the BFI57 is supplied with power.

Additionally this D-SUB socket incorporates an RS-232 interface. This RS-232 interface is used for the output of flight information, as well as for maintenance (calibration and firmware updates). For further explanations regarding the output messages refer to Annex 5.2.

| D-Sub-Connector Pin-Out and Cable Colors/Cross-Sections | | | | | |
|---|-------|----------------------|---|----------------------------|---|
| PIN # | Color | Cross-Sctn. | Function | | |
| 1+2 *) | red | 0.96 mm ² | Power-Supply – Input +8 to +18 VDC <u>Use with external switch</u> (e.g. Avionics Master) <u>Use external 2A fuse (slow-blow)</u> | | |
| 3 | | | – | | |
| 4+5 *) | blue | 0.96 mm ² | Power-Supply – Ground | | |
| 6 | | | – | | |
| 7 | black | 0.38 mm ² | RS232 Output TX (see 5.2) | Pin # Data Connector | 3 |
| 8 | white | 0.38 mm ² | RS232 Input RX | | 1 |
| 9 | blue | 0.38 mm ² | RS232 Signal Ground | | 5 |
| *) internally connected within the cable set delivered with the product | | | | | |

Rear View:

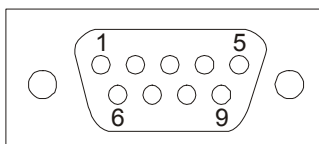

Data Connector:

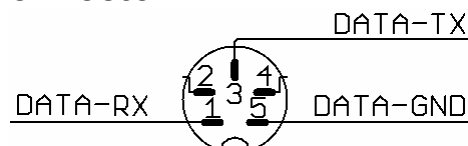

Binder Connector Male
seen from solder side

(both seen from aircraft side)

0.96 mm² can be substituted by AWG17, 0.38 mm² by AWG21.

The power supply has the following requirements:

- Voltage: 8 ... 18 V DC
- Power Consumption: < 10W charging, < 3W operating charged, < 150mW standby charged



As the BFI57 is designed to be useful as backup device for glass cockpit equipped aircraft, the “off” state in reality is a standby, which (depending onto configuration) even allows charging of the internal battery.

To avoid that with a parked aircraft the standby power consumption empties the aircraft battery, between the BFI57 and the aircraft battery (e.g. an Avionics Master) is absolutely mandatory.

3.6 Device Dimensions

3.6.1 Housing

The BFI57 is designed to be installed in a cockpit panel with a standard 2 ¼ inch (57 mm) diameter cut-out.



The device has the following dimensions:

Width: 65 mm (2.56")
 Height: 65 mm (2.56")
 Depth: 107 mm (4.22") (without front plate and connectors)

After installation the visible part (round element) has the following dimensions:

Diameter: 57 mm (2.25") Thickness: 2 mm (0.08")

3.6.2 Installation Hints

Connection area

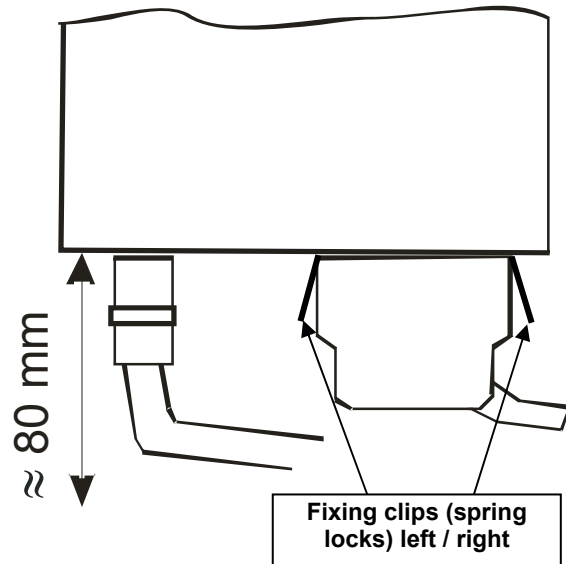

Panel cut out

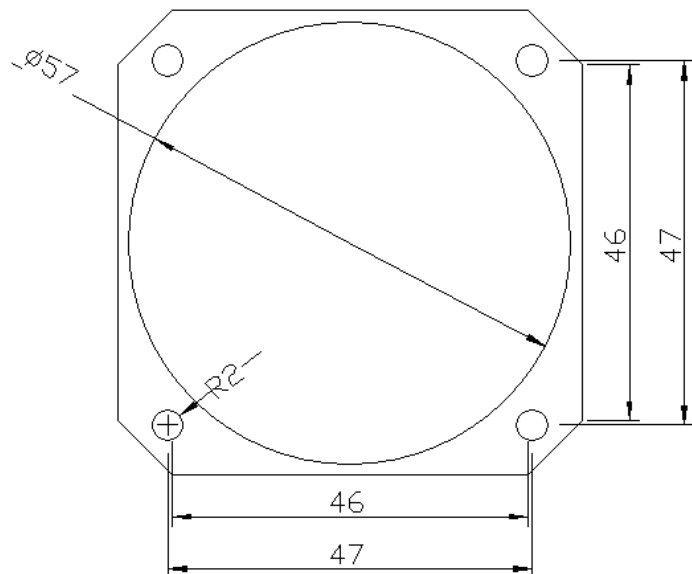

The D-SUB-Connector has to be clamped with both **spring locks**. It is recommended to additionally secure them **with a cable tie**.

3.7 Post-Installation Checks

All control functions of the aircraft must be checked to eliminate risk of interference due to wiring.

3.8 Device Configuration

The device configuration comprises basic settings, which need to be done after installation prior the operational usage of the device, incl.:

- Charging Behaviour (always or only during operation)
- Borders of Coloured Areas within the IAS-Tape

| | |
|---|--|
|  | <p>The configuration of the colour bands of the IAS tape needs to be done carefully in order to avoid misleading indications of velocity ranges!</p> |
|---|--|

The device configuration is not accessible from the normal operation mode. To access the configuration, **switch the device on or reboot with I/O** while holding the **DIM** and **QNH +** buttons in the moment when releasing **I/O**.

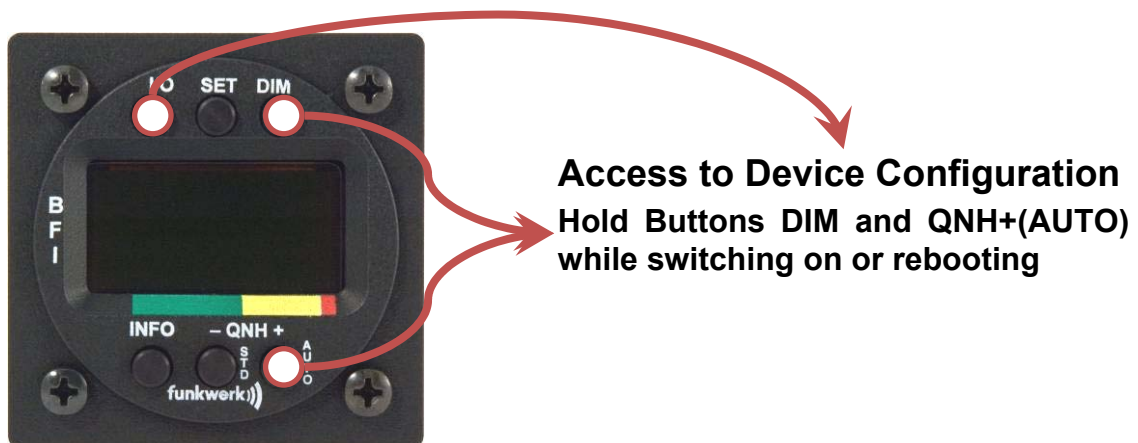

The individual configuration items are **run through with INFO**.

The device configuration is **automatically left** after stepping through all options and can additionally be left earlier by pressing **SET**.

3.8.1 Switching-On Behaviour



This configuration option defines whether the device shall be switched on manually (**manu**) or whether shall turn on automatically whenever power is supplied (**alw**).

If option “**alw**” is active (white underlined) the device cannot be switched off as long as power is available.

Even when set to “**alw**” the device can additionally be turned on manually when no power is supplied.

3.8.2 Charging Behaviour



Defines when the battery shall be charged.

alw whenever power is available

on only when turned on

3.8.3 IAS Tape – Colour Markers

The colour markers which correspond to the printed colour bands on the housing are defined by the lower border. The upper limit results from the defined lower limit of the next colour band. The indication of the white colour band is activated separately. The white colour band is then defined by its lower and upper limit.

3.8.3.1 IAS-Tape – Green (GRN) Band

Defines **lower limit** of the green colour band.

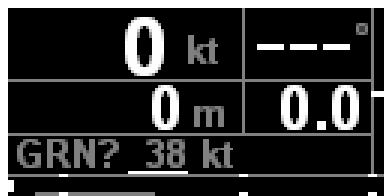

The value of the lower limit is adjusted with the setting buttons **- QNH +**. The unit of this speed value is the same as the one configured for the indicated airspeed (IAS) **km/h** or **kt**.

3.8.3.2 IAS-Tape – Yellow (YEL) Band

Defines **lower limit** of the yellow colour band.

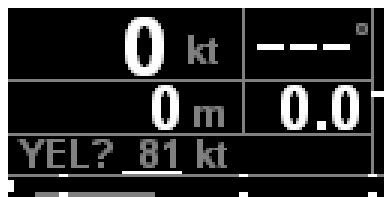

The value of the lower limit is adjusted with the setting buttons **- QNH +**. The unit of this speed value is the same as the one configured for the indicated airspeed (IAS) **km/h** or **kt**.

3.8.3.3 IAS-Tape – Red (RED) Band

Defines **lower limit** of the red colour band.

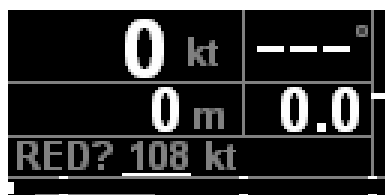

The value of the lower limit is adjusted with the setting buttons **- QNH +**. The unit of this speed value is the same as the one configured for the indicated airspeed (IAS) km/h or kt.

3.8.3.4 IAS-Tape – White (WHT) Band

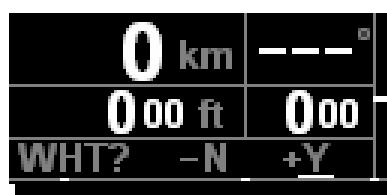

Additionally to the printed colour bands the white colour band corresponding to the velocity range with extended flaps can be shown on the screen.

N No → no white colour band will be displayed; the following configuration steps defining lower and upper limit are not required and will be skipped.

Y Yes → depending on the display illumination **DIM** the white colour band appears as grey or white band. The configuration is done in the next two steps.

3.8.3.5 IAS-Tape – White (WLO) Lower Limit

In case the indication of the white colour band has been activated (see 3.8.3.4), now the **lower limit** of the white colour band is defined.



The value of the lower limit is adjusted with the setting buttons **- QNH +**. The unit of this speed value is the same as the one configured for the indicated airspeed (IAS) km/h or kt.

3.8.3.6 IAS-Tape – White (WHI) Upper Limit

In case the indication of the white colour band has been activated (see 3.8.3.4), now the **upper limit** of the white colour band is defined.

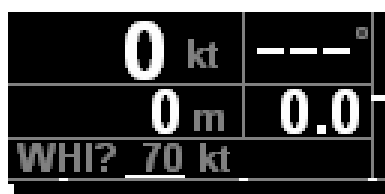

The value of the lower limit is adjusted with the setting buttons **- QNH +**. The unit of this speed value is the same as the one configured for the indicated airspeed (IAS) **km/h** or **kt**.

3.8.3.7 IAS-Tape – Marker Position (MRK)

To allow manually attaching of markings in addition to the coloured ranges (e.g. attaching a little yellow triangle for V_{REF}), this configuration step displays a small line within the IAS-Tape with adjustable position.



It's position is adjusted with the setting buttons **- QNH +**. The unit of this speed value is the same as the one configured for the indicated airspeed (IAS) **km/h** or **kt**.

The chosen value is not memorized.

The configuration is ended with another press of **INFO**; the display changes into normal operation mode.

3.9 Firmware Update

The following is required for performing firmware updates:

- Standard Windows™ PC
- Update program (available as download from the Service area of www.funkwerk-avionics.com)
- Data cable (available with order-no. ZATRUSB)

The firmware update is performed as follows:

1. Connect BFI57 and PC using the data cable.
2. Start the update program on the PC.
3. Restart the BFI57 by pressing **I/O** for 10 seconds; hold both **SET** and **INFO** pressed when releasing **I/O** and additionally for 2 seconds longer. The device shows when being in firmware update mode.
4. Start the transfer by pressing a key on the PC.
5. After end of the transfer restart the BFI57 again by pressing **I/O** for 10 seconds (this time without **SET**).

4 STORAGE AND DISPOSAL

The BFI57 comes with a pre-installed Lilon battery. In order to avoid a total discharge **in case of disuse the device should to be charged every 3 months.**

For an optimum number of charging cycles the Lilon battery should be stored partially charged (neither fully charged nor completely discharged).

The ideal storage temperature is about 15°C.



Never store the device over extended periods with empty battery, as the resulting deep discharge permanently damages the battery.



The Lilon battery must not be recycled with residential waste. The Lilon battery must be recycled separately and in a professional manner.

5 APPENDICES

5.1 Technical Data

| | | |
|---|--|-------------------------|
| Display Ranges | | |
| Speed | 0 to 400 km/h | 0 to 200 kts |
| Altitude | -300 to +10.000 m | -1.000 to +30.000 ft |
| Rate of Climb | -19,9 to +19,9 m/s | -1.999 to +1.999 ft/min |
| QNH | 940 to 1050 hPa | 27,76 to 31,00 mm HG |
| Colour markings airspeed | Green, Yellow, Red fix marked at the device, White in display. All in configurable scaling. | |
| Temperature Areas | | |
| Operation | -20 °C to +70 °C | |
| Battery Charging | -15 °C to +45 °C | |
| Storage | -30 °C to +85 °C | |
| Power Supply / Power Consumption | 12 VDC (8 VDC ... 18 VDC) < 10W Charging battery < 3W Operation, battery charged < 150mW Standby, battery charged | |
| Protection | external 2-A-fuse (slow-blow) | |
| Mounting | Installation cut out diameter $\varnothing = 57.5$ mm | |
| Weight | Device approx. 430 g / Complete set (incl. antenna+cable) <600g | |
|  -Conformity | This device is produced in line with european standards and satisfies the given safety criterias. | |

The BFI57 is factory-provided with a Lilon battery, which in case of defect must be recycled separately and in a professional manner!

5.2 Outputs at the Serial Interface

The RS-232 interface outputs pressure derived measurements as well as the GPS position.

5.2.1 Output Protocol

The communication is in "NMEA / pseudo NMEA", with device specifier "PFA".

The checksum is the 8-bit XOR of all characters in the sentence including the "," delimiters, between but not including the "\$" and "*" characters.

All output messages are terminated with <CR><LF>.

All other messages than those listed below have to be ignored.

5.2.2 GPS Messages

The following messages of the internal GPS receiver are echoed at the serial port to the outside, with the same data rate as generated by the internal GPS receiver (i.e. 4–5Hz):

\$GPRMC \$GPGGA

5.2.3 BFI57-specific Output Messages

The following proprietary messages are generated by the BFI57. They are inserted between the GPS messages.

Indicated Airspeed

This information will be sent with about 5 Hz rate.

\$PFA,IAS,vv.v,u*hh

| | |
|------|---|
| IAS | fixed string, identifying indicated airspeed message |
| vv.v | indicated airspeed in the unit specified in the following, with one digit after the decimal, never negative |
| u | indicating airspeed unit N=kt, K=km/h |
| *hh | Checksum |

Barometric Altitude

This information will be sent with about 5 Hz rate.

\$PFA,ALT,*aaaaa*,*u*,*qqqq*,*v*,*m*hh*

| | |
|--------------|---|
| ALT | fixed string, identifying barometric altitude message |
| <i>aaaaa</i> | altitude in the unit specified as follows, integer value |
| <i>u</i> | Unit in which altitude is indicated, F=ft, M=m |
| <i>qqqq</i> | QNH value used for this altitude, integer value for the unit hPa, two decimal digits inHG |
| <i>v</i> | QNH unit, H=hPa, I=inHG |
| <i>m</i> | QNH Mode: M = when manually set A = when automatically determined |
| <i>*hh</i> | Checksum |

Barometric Rate of Climb

This information will be sent with about 5 Hz rate.

\$PFA,ROC,*rrr*,*u*hh*

| | |
|------------|---|
| ROC | fixed string, identifying rate of climb message |
| <i>rrr</i> | Rate of climb in the unit specified as follows, integer value for the unit ft/min, with two digits after the decimal for the unit m/s |
| <i>u</i> | Rate of climb unit, F=ft/min, M=m/s |
| <i>*hh</i> | Checksum |

Flight Status

This information will be sent with about 1 Hz rate.

Change in flight state may be delayed up to 10 seconds. The takeoff and landing time, however, are then reported taking the delay into account (indicating events a few second ago, and therefore not being in-line with the GPS time stamps).

When on ground, data for last flight is transmitted until power-down. When powered on while on ground, empty data is transmitted until takeoff.

A new takeoff overwrites the data from a previous flight, including landing time.

`$PFA,FLT,f,s,dddddd,tttt,u,llll,v,aaaaa*hh`



| | |
|---------------|--|
| FLT | fixed string, identifying flight status message |
| <i>f</i> | flight status: F = in flight G = on ground |
| <i>s</i> | determination source for flight status, I for IAS, G for GPS |
| <i>dddddd</i> | date of takeoff in format DDMMYY, empty before takeoff |
| <i>tttttt</i> | time of takeoff in format HHMMSS, empty before takeoff |
| <i>u</i> | reference system of takeoff time is UTC |
| <i>llllll</i> | time of landing in format HHMMSS, empty before landing |
| <i>v</i> | reference system of landing time is UTC |
| <i>aaaaaa</i> | duration airborne in format HHMMSS, empty before takeoff |
| <i>*hh</i> | Checksum |

Notes:

BFI57 / P/N BFI57-(xxx)-(xxx)

Operation and Installation



| | |
|--|---|
|  EG-Konformitätserklärung <i>EC-Declaration of Conformity</i> <i>CE-Déclaration de conformité</i> | |
| Hersteller / Manufacturer / Fabricant | Funkwerk Avionics GmbH |
| Anschrift / Address / Adresse | Gewerbestrasse 2 D-86875 Waal Germany |
| Produktbezeichnung / Product specification / Description du produit | Basic Flight Instrument |
| Typen / Types / Types | BFI57 |
| Wir erklären in alleiniger Verantwortung, daß das (die) oben bezeichnete Produkt(e) mit folgenden Europäischen Richtlinien übereinstimmt (übereinstimmen) / <i>We declare under our sole responsibility that above product(s) is (are) in conformity with the following directives /</i> <i>Déclarons sous notre seule responsabilité, que le(s) produit(s) repond(ent) aux directives suivantes</i> | 2004/108/EG EMV Richtlinie 2004/108/EC EMC Directive 2004/108/CE Directive CEM |
| Angewandte harmonisierte Normen und technischen Spezifikationen / <i>Applied harmonised standards and technical specifications /</i> <i>Normes harmonisées et spécifications techniques:</i> | EN 55022:2006 + A1:2007 EN 55024:1998 + A1:2001 + A2:2003 |
| Benannte Stelle und Nummer der EG-Baumusterprüfbescheinigung / <i>Notified Body and number of the EC-type-examination certificate /</i> <i>Organisme agréé et numéro du certificate des test CE</i> | n/a |
| Ort, Datum der Ausstellung / <i>Place, date of issue / Lieu, date de l'édition</i> | Waal, 01.06.2010 |
| Revision | 1.0 |
| Name und Unterschrift des Befugten / <i>Name and signature of authorized person /</i> <i>Nom et signature de la personne autorisée:</i> |  <hr style="width: 100%; border: 0; border-top: 1px dotted black;"/> Dr. Thomas Wittig |

| | |
|---|---|
|  | Umweltinformationen für Kunden innerhalb der Europäischen Union <i>Regulatory and Compliance/WEEE Legislation within the European Union</i> |
| <p>Gemäß der Europäischen Richtlinie 2002/96/EG über Elektro- und Elektronik-Altgeräte (WEEE) und die Änderung 2008/34/EG dürfen Produkte, die direkt am Gerät und/oder an der Verpackung mit diesem Symbol versehen sind, nicht zusammen mit gewöhnlichem Abfall entsorgt werden, sondern sind über die für elektrische und elektronische Geräte zuständigen und von der Regierung oder örtlichen Behörden dazu bestimmten Sammelstellen zu entsorgen. Ordnungsgemäßes Entsorgen und Recyceln trägt dazu bei, potentielle negative Folgen für Umwelt und die menschliche Gesundheit zu vermeiden. Wenn Sie weitere Informationen zur Entsorgung Ihrer Altgeräte benötigen, wenden Sie sich bitte an die örtlichen Behörden oder städtischen Entsorgungsdienste oder an den Händler, bei dem Sie das Produkt erworben haben.</p> <p><i>According to the European directive 2002/96/EC on waste electrical and electronic equipment (WEEE) an the amendment 2008/34/EC: Products, that are marked with the above symbol directly at the device and/or at the packaging, may not to be disposed together with ordinary waste, but have to be disposed using the appropriate differentiated collection centres for electronic and electro waste. Appropriate differentiated waste collection and recycling helps to prevent possible negative environmental and health effects. If you need additional information about the disposal of your products after the end of their working life, please contact your local authorities or municipal waste disposal organisation, or the dealer you have purchased the product from.</i></p> | |

Funkwerk Avionics GmbH

Gewerbestraße 2
D-86875 Waal
Germany

phone.: +49-8246 9699 0

fax.: +49-8246 1049

E-mail:

service@funkwerk-avionics.com

www.funkwerk-avionics.com